

微距型角形永磁夾盤 Rectangular Micropitch Permanent Magnetic Chuck

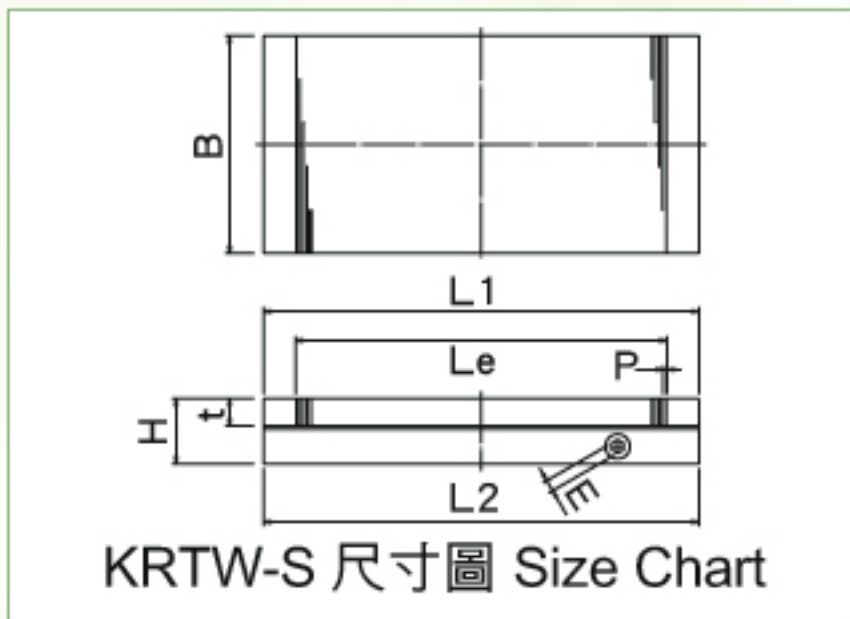

鐘通工業股份有限公司
KANETSU KOGYO CO., LTD.

KRTW-A/KRTW-S

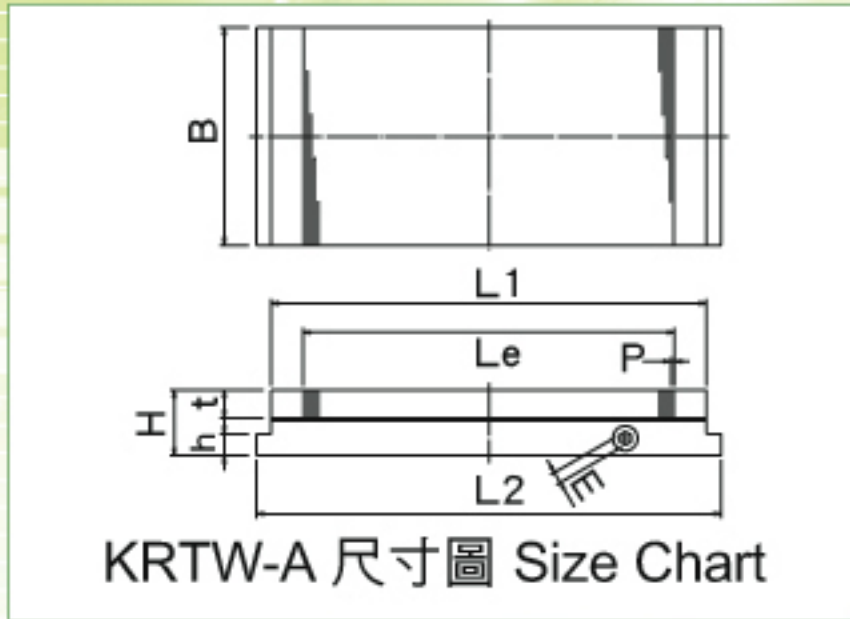

用途:

微距型永磁夾盤，厚度45mm，在磨削及放電加工上無論薄的或較小的工件都能有效發揮吸著力。其特色夾盤面有效磁力範圍面積廣大。

特性:

- 重量輕，厚度薄，適合多種用途。
- 此微距型永磁夾盤有良好磁距設計，非常適用於小型或薄的工件。
- 夾盤開關採六角扳手ON/OFF轉換，操作與抽取工件容易。
- 夾盤面比其他類似之夾盤有較寬大的有效磁力範圍。

Application:

Lower height permanent magnetic chuck has 45mm thickness, and it is suitable for grinding and electric discharging process of thin plate or small workpieces. It features a wide effective magnetic area on the chucking face.

Features:

- Thin and light weight to meet versatile machining process.
- The micropitch permanent magnetic chuck that has fine-Pitched magnetic poles, makes it ideally suitable for small and thin workpieces.
- Hexagonal wrench key is used for the On/Off switch and it is easy to operate and remove.
- The chuck surface has a wider effective magnetic area than other similar type of permanent magnetic chucks.

規格表 Specification Table

mm

型式 Model	尺寸 Nominal Dimension	夾盤作業面 Chucking Face				磁極間隔 Pole Pitch P	夾盤基準面 Chuck Mounting Part			高度 Height H	六角孔 Hexagonal Handle hole E	重量 Weight
		B	L1	Le	t		B	L2	h			
KRTW-1018A	100×175	100	175	146	19	2.5(1+1.5)	100	195	15	45	8	6.0Kg
KRTW-1515A	150×150	150	150	121	19	2.5(1+1.5)	150	170	15	45	8	8.0Kg
KRTW-1530A	150×300	150	300	256	19	2.5(1+1.5)	150	320	15	45	8	16.0Kg
KRTW-1535A	150×350	150	350	306	19	2.5(1+1.5)	150	370	15	45	8	18.5Kg
KRTW-1540A	150×400	150	400	356	19	2.5(1+1.5)	150	420	15	45	8	21.0Kg
KRTW-1545A	150×450	150	450	406	19	2.5(1+1.5)	150	470	15	45	8	24.0Kg
KRTW-2035A	200×350	200	350	306	19	2.5(1+1.5)	200	370	15	45	8	25.0Kg
KRTW-2040A	200×400	200	400	356	19	2.5(1+1.5)	200	420	15	45	8	28.5Kg
KRTW-2045A	200×450	200	450	406	19	2.5(1+1.5)	200	470	15	45	8	32.0Kg
KRTW-2050A	200×500	200	500	456	19	2.5(1+1.5)	200	520	15	45	8	36.0Kg
KRTW-2060A	200×600	200	600	556	19	2.5(1+1.5)	200	620	15	45	8	43.0Kg
KRTW-1018S	100×175	100	175	146	19	2.5(1+1.5)	100	175	-	45	8	5.5Kg
KRTW-1515S	150×150	150	150	121	19	2.5(1+1.5)	150	150	-	45	8	7.5Kg
KRTW-1530S	150×300	150	300	256	19	2.5(1+1.5)	150	300	-	45	8	15.5Kg